



NEX90015BDG-Q100 150 mA, 40 V low Iq (5.3 μ A) LDO evaluation board



Abstract: This user manual describes the NEX90015BDG-Q100 evaluation board (EVB). The NEX90015BDG-Q100 is a 40 V, 150 mA low-dropout (LDO) linear regulator with only 5.3 μ A typical quiescent current at light load for automotive always on/stand by applications. This document contains the EVB schematic and configuration, bill of materials (BOM) and board layouts.

Keywords: NEX90015BDG-Q100, LDO linear regulator, ultra-low operating quiescent current, evaluation board

1. Introduction

This evaluation board is designed for NEX90015BDG-Q100. The NEX90015BDG-Q100 device is an LDO designed for up to 40 V input voltage with maximum 150 mA output current. The EVB helps engineers to evaluate the operation and performance of NEX90015BDG-Q100.

1.1. Features

The following features are available on this EVB:

- Input voltage range: 3 V to 40 V
- Output voltage and current:
 - 3.3 V/150 mA
 - 5 V/150 mA

1.2. Applications

NEX90015BDG-Q100 is used in the following applications:

- Body control modules (BCMs)
- Automotive lighting
- Automotive head units & clusters
- Telematics control units
- Powertrain of electric vehicles (EV) and hybrid electric vehicles (HEV)

1.3. Target EVBs for this document

This user manual is applicable to the EVBs listed in [Table 1](#).

Table 1. Target EVBs and type numbers

Target EVBs	Type number
NEVB-NEX90015BDG	NEX90015BDG-Q100
NEVB-NEX90015ADG	NEX90015ADG-Q100

2. Schematic

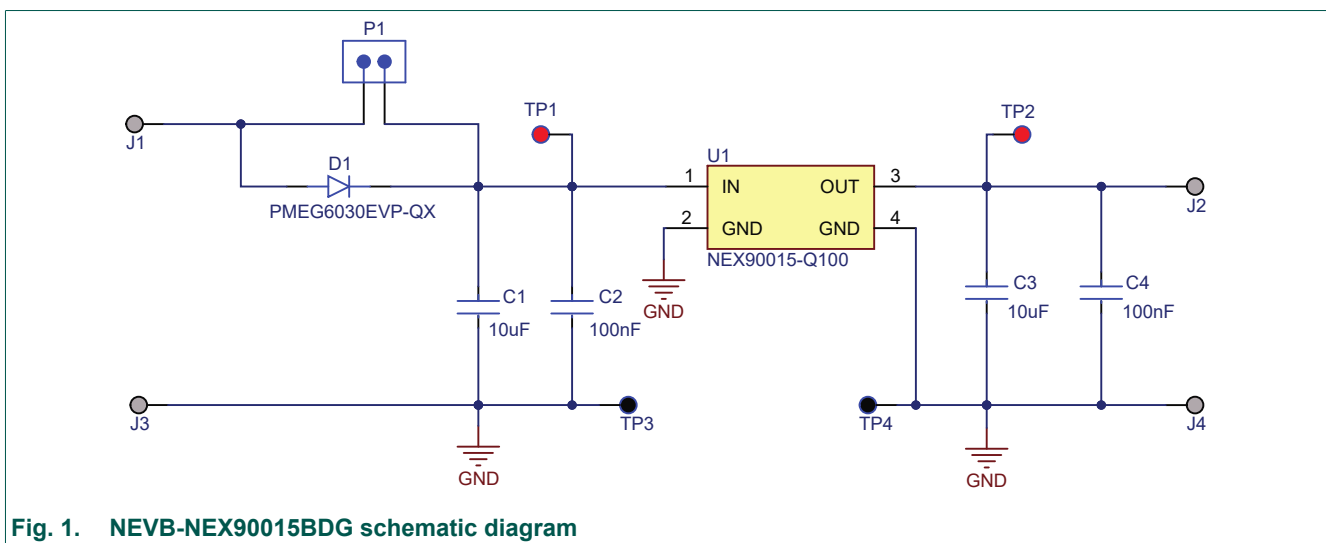

3. General configuration and description

This section describes the connectors and test points on the EVB and how to properly connect, set up and use the NEVB-NEX90015BDG.

3.1. Physical access

[Table 2](#) lists the NEVB-NEX90015BDG connectors and test point functionality.

Table 2. Connectors and test points

Connector	Label	Descriptions
J1	VBAT	This connector is the input of the EVB
J2	OUT	This connector is the output of the EVB
J3, J4	GND	These connectors are the ground connector of the EVB
P1	N/A	This jumper is for bypass of reverse diode D1
TP1	IN	Device input test point
TP2	OUT	Output test point
TP3, TP4	GND	Ground test points

3.2. Test setup

The following steps show how to set up this EVB.

1. P1 is floating to connect the reverse diode or short together to bypass the reverse diode.
2. Connect a power supply with positive voltage between J1 (VBAT) and J3 (GND) connectors, and ensure that the input range is 3 V to 40 V.
3. Connect a load from 0 mA to 150 mA between the J2 (OUT) and J4 (GND) connectors.
4. Turn on the input power supply.
5. Measure the respective parameters by using test points (TP1 to TP4).

4. PCB layout

Figure 2 and Figure 3 show the PCB layouts for the NEVB-NEX90015BDG.

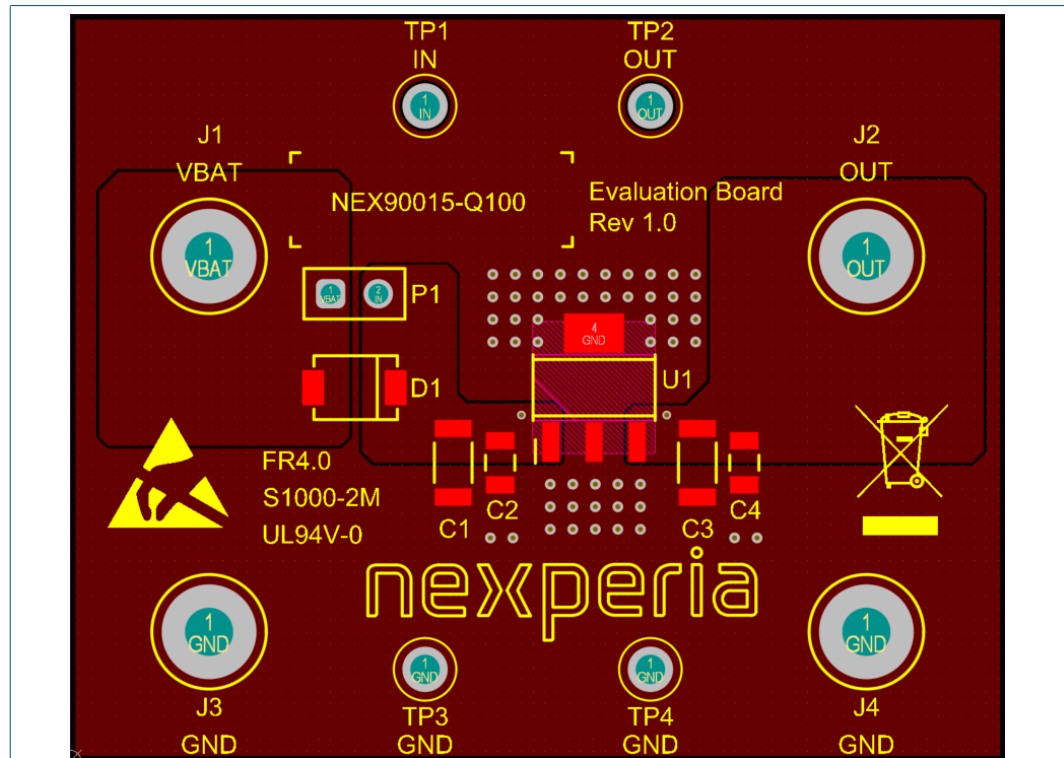

Fig. 2. NEVB-NEX90015BDG top layer routing

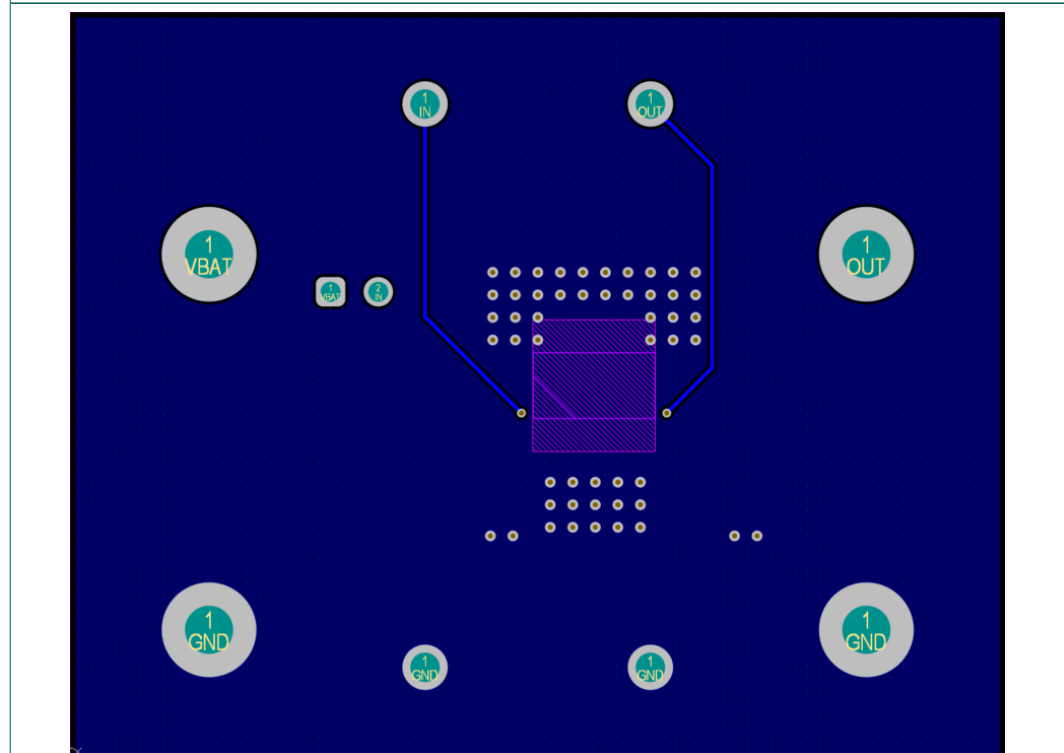

Fig. 3. NEVB-NEX90015BDG bottom layer routing

5. Bill of materials

[Table 2](#) details the bill of materials of NEVB-NEX90015BDG.

Table 3. Bill of materials (BOM)

Designator	Value	Description	Quantity	Part number	Manufacturer
C1	10 μ F	Cap Ceramic 10 μ F 50 V X7R 10% Pad SMD 1206 125 °C Automotive T/R	1	CGA5L1X7R1H106KT0Y0N	TDK
C2, C4	100 nF	Cap Ceramic 100 nF 100V X7R 10% Pad SMD 0805 125 °C Automotive T/R	2	CGA4J2X7R2A104K125AA	TDK
C3	10 μ F	Cap Ceramic 10 μ F 16 V X7R 10% Pad SMD 1206 125 °C Automotive T/R	1	CGA5L1X7R1C106K160AC	TDK
D1	SMA	PMEG6030EVP-Q - High-temperature 60 V, 3 A Schottky barrier rectifier	1	PMEG6030EVP-QX	Nexperia
J1, J2, J3, J4	TH	Terminal DBL Turret, Through Hole, RoHS	4	1502-2	Keystone Electronics
P1	TH	CONN HEADER VERT 2POS 2.54 MM	1	61150211121	We-online
R1	10 k Ω	RES Thick Film, 10 k Ω , 5%, 0.1 W, 200 ppm/°C, 0603	1	RC0603FR-0710KL	YAGEO
TP1, TP2	TH	PC TEST POINT COMPACT BLACK	2	5005	Keystone Electronics
TP3, TP4	TH	PC TEST POINT COMPACT BLACK	2	5006	Keystone Electronics
U1	-	150 mA High Voltage Ultra-Low Iq Low Dropout Regulator	1	NEX90015-Q100	Nexperia

6. Revision history

Table 4. Revision history

Revision number	Release date	Description
UM90088 v. 1	20260128	Initial version

7. Legal information

Definitions

Draft — The document is a draft version only. The content is still under internal review and subject to formal approval, which may result in modifications or additions. Nexperia does not give any representations or warranties as to the accuracy or completeness of information included herein and shall have no liability for the consequences of use of such information.

Disclaimers

Limited warranty and liability — Information in this document is believed to be accurate and reliable. However, Nexperia does not give any representations or warranties, expressed or implied, as to the accuracy or completeness of such information and shall have no liability for the consequences of use of such information. Nexperia takes no responsibility for the content in this document if provided by an information source outside of Nexperia.

In no event shall Nexperia be liable for any indirect, incidental, punitive, special or consequential damages (including - without limitation - lost profits, lost savings, business interruption, costs related to the removal or replacement of any products or rework charges) whether or not such damages are based on tort (including negligence), warranty, breach of contract or any other legal theory.

Notwithstanding any damages that customer might incur for any reason whatsoever, Nexperia's aggregate and cumulative liability towards customer for the products described herein shall be limited in accordance with the Terms and conditions of commercial sale of Nexperia.

Right to make changes — Nexperia reserves the right to make changes to information published in this document, including without limitation specifications and product descriptions, at any time and without notice. This document supersedes and replaces all information supplied prior to the publication hereof.

Suitability for use — Nexperia products are not designed, authorized or warranted to be suitable for use in life support, life-critical or safety-critical systems or equipment, nor in applications where failure or malfunction of an Nexperia product can reasonably be expected to result in personal injury, death or severe property or environmental damage. Nexperia and its suppliers accept no liability for inclusion and/or use of Nexperia products in such equipment or applications and therefore such inclusion and/or use is at the customer's own risk.

Applications — Applications that are described herein for any of these products are for illustrative purposes only. Nexperia makes no representation or warranty that such applications will be suitable for the specified use without further testing or modification.

Customers are responsible for the design and operation of their applications and products using Nexperia products, and Nexperia accepts no liability for any assistance with applications or customer product design. It is customer's sole responsibility to determine whether the Nexperia product is suitable and fit for the customer's applications and products planned, as well as for the planned application and use of customer's third party customer(s). Customers should provide appropriate design and operating safeguards to minimize the risks associated with their applications and products.

Nexperia does not accept any liability related to any default, damage, costs or problem which is based on any weakness or default in the customer's applications or products, or the application or use by customer's third party customer(s). Customer is responsible for doing all necessary testing for the customer's applications and products using Nexperia products in order to avoid a default of the applications and the products or of the application or use by customer's third party customer(s). Nexperia does not accept any liability in this respect.

Export control — This document as well as the item(s) described herein may be subject to export control regulations. Export might require a prior authorization from competent authorities.

Translations — A non-English (translated) version of a document is for reference only. The English version shall prevail in case of any discrepancy between the translated and English versions.

Trademarks

Notice: All referenced brands, product names, service names and trademarks are the property of their respective owners.

Contents

1. Introduction	2
1.1. Features.....	2
1.2. Applications.....	2
1.3. Target EVBs for this document.....	2
2. Schematic	2
3. General configuration and description	3
3.1. Physical access.....	3
3.2. Test setup.....	3
4. PCB layout	4
5. Bill of materials	5
6. Revision history	5
7. Legal information	6

© Nexperia B.V. 2026. All rights reserved

For more information, please visit: <http://www.nexperia.com>
For sales office addresses, please send an email to: salesaddresses@nexperia.com
Date of release: 28 January 2026
