

Power OR-ing without compromise: The NID5100 Ideal Diode

NID5100 1.2 V - 5.5 V, 1.5 A Input Polarity Protected, Ideal Diode

Power Management Ideal Diode ICs

Ideal diodes are electrically efficient, low leakage integrated circuit replacements for traditional Schottky power diodes commonly used in mission critical power OR-ing applications. Compared to similarly rated traditional Schottky diodes, ideal diodes provide three key advantages:

	Schottky diode	ideal diode	
Forward biased ($V_{ANODE} - V_{CATHODE}$)	200 ~ 500 mV	7 ~ 50 mV	10 to 30x lower power loss
Reverse biased DC leakage current	5 μ A ~ 3 mA	< 1 μ A	5 to 3000x lower reverse leakage
Package thermal rating $R_{\theta JA}$	400 K/W (SOT323)	256 K/W (TSSOP6)	Larger thermal margin

In the industrial space, ideal diodes are favored over traditional Schottky diodes for their lower forward voltage drop, as well as for their thermal performance. In automotive power systems, ideal diodes play a crucial role by guarding against reverse polarity conditions protecting expensive modules from damage.

Features and benefits

- › Low loss replacement for power OR-ing diodes
 - Forward regulation voltage: 31 mV (typ)
 - Supports forward current up to 1.5A
- › Automatic transition between OR-ed supplies
- › Operating voltage range 1.2V to 5.5V
- › Low current consumption
 - 3.3V V_{IN} shutdown current ($I_{IN(SD)}$): 170nA
 - 3.3V V_{IN} quiescent current ($I_{IN(Q)}$): 240nA
- › Reverse voltage protection V_{IN} : - 6V abs max
- › Output status indication (ST)
- › Available in standard and AEC-Q100 (Grade 1)

Key applications

- › OR-ed primary and backup power
- › Smart meters
- › Battery powered wearables
- › Automotive telematics
- › Automotive ADAS

Nexperia Ideal Diodes

An ideal diode IC (Integrated Circuit) is a semiconductor device designed to emulate the behavior of an ideal diode, which allows current to flow in one direction with minimal forward voltage drop and negligible reverse leakage current. Unlike traditional diodes, which have significant voltage drops and reverse leakage currents, ideal diode ICs use advanced circuitry to achieve near-perfect diode characteristics.

Low Forward Conduction Loss

In traditional systems, the forward voltage drop of Schottky diodes leads to increased forward conduction power loss and often requires thermal management solutions like heat sinks, which in turn require more PCB space and raise overall costs. To correct this issue, the NID5100 utilizes an internal P-MOSFET to significantly reduce the forward voltage drop to as low as 31 mV. This approach not only minimizes power loss, but also reduces the need for extensive thermal management, thereby enhancing efficiency and reducing costs.

Low Current Consumption

In many applications, maintaining an extremely low shutdown current and quiescent current is crucial to meet the overall system requirement of less than a few hundred μA . This is even more crucial when multiple battery-powered subsystems are involved. The NID5100 excels in this regard, featuring a maximum shutdown current of only 170 nA and a quiescent current of 240 nA. This low shutdown and quiescent current not only satisfies stringent automotive system requirements, but also benefits various other battery-powered or energy-harvesting applications where minimal power consumption is essential. This makes the NID5100 an ideal choice for enhancing efficiency and prolonging battery life in diverse low-power systems.

Reverse Polarity Protection

The NID5100 provides effective reverse polarity protection by leveraging its integrated MOSFET and control circuitry. When reverse voltage up to -6V is detected, the MOSFET is rapidly turned off. This quick response prevents damage to sensitive components and ensures that the system remains operational despite incorrect power connections. In automotive/industrial applications, where incorrect battery connections can occur, ideal diode ICs protect critical electronic components from damage, ensuring the system's electrical system remains functional.

Ordering information

Part number	Package			
	Temperature range	Name	Description	Version
NID5100GW	$-40\text{ }^{\circ}\text{C}$ to $+125\text{ }^{\circ}\text{C}$	TSSOP6	Plastic thin shrink small outline package; 6 leads; body width 1.25 mm	SOT363-2
NID5100GW-Q100	$-40\text{ }^{\circ}\text{C}$ to $+125\text{ }^{\circ}\text{C}$	TSSOP6	Plastic thin shrink small outline package; 6 leads; body width 1.25 mm	SOT363-2

© 2024 Nexperia B.V.

All rights reserved. Reproduction in whole or in part is prohibited without the prior written consent of the copyright owner. The information presented in this document does not form part of any quotation or contract, is believed to be accurate and reliable and may be changed without notice. No liability will be accepted by the publisher for any consequence of its use. Publication thereof does not convey nor imply any license under patent- or other industrial or intellectual property rights.

nexperia.com

Reverse Current Blocking (RCB)

Reverse current blocking (RCB) protection is always active in the NID5100, regardless of the state of EN. When EN is low and the output is forced above the input, the internal P-MOSFET will switch off to stop the reverse current. When the IN-to-OUT differential returns below its internally set trip point, the device will turn back on and regulate IN to OUT at VREG. When the EN pin voltage is high, the internal PMOS is turned off and reverse current blocking (RCB) occurs through body diode action when VOUT is greater than the input voltage.

Power Supply OR-ing and Paralleling

There is no specific limitation to the number of NID5100 ideal diodes used for power OR-ing. The example below illustrates a common two power supply scenario with smooth transitions between supplies.

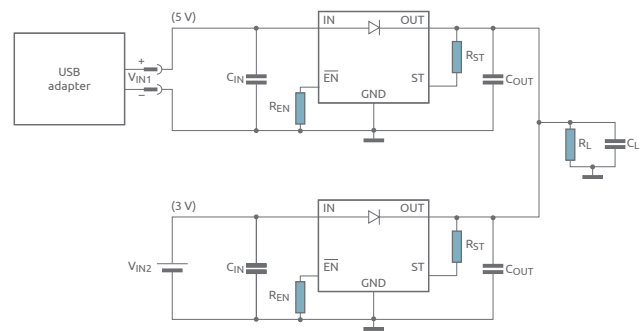

Fig 1. NID5100 OR-ing power supply scenario

The NID5100 can also be configured in parallel to sustain high currents and maintain thermal efficiency. This sharing of the load current can lead to lower internal power dissipation in system designs.

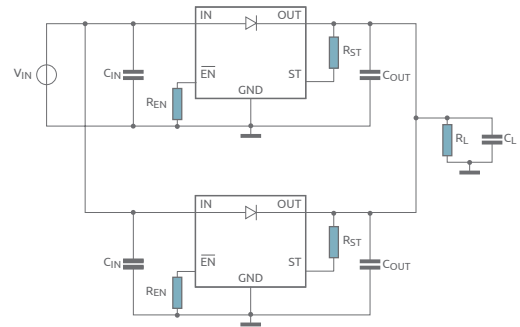

Fig 2. NID5100 parallel power supply scenario

Date of release:

July 2024

