

Using shift registers to reduce size and BOM in LED designs

by Michael Lyons, NXP Semiconductor

Summary

Shift registers can help reduce size and BOM in designs that use LEDs. By providing I/O expansion, they enable the use of smaller, less expensive microcontrollers. In some cases, the shift register can be used to drive the LED directly and thus eliminate the need for external LED drivers. This adds to the savings, and makes it possible to drive a wider variety of LEDs.

Full Article

In designs that use LEDs, shifter registers can be very useful. For instance, if the system includes a seven-segment display, a single indicator, or an array of LEDs that form a grid or panel, a standard 8-bit shift register can be used to allow a low pin-count microcontroller to drive multiple LEDs.

Figure 1 gives an example. A single 5V 74HC595 shift register, with serial inputs and serial or parallel outputs, provides I/O expansion for the microcontroller. Serial data is applied to the serial input of the 74HC595 and clocked in via the input clock. Once the 74HC595 is loaded, the output clock applies the data to the storage register and to the parallel and serial outputs. External drivers, controlled by the 74HC595, then activate the corresponding LEDs.

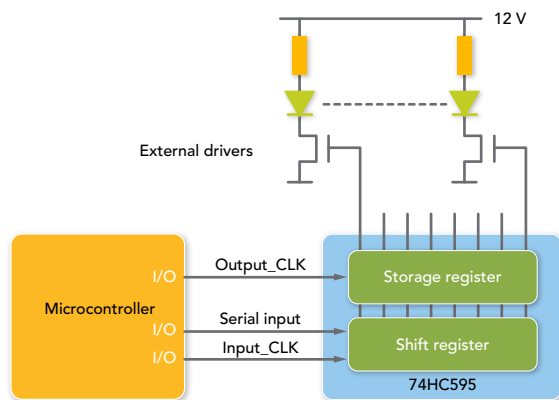

Figure 1. An 8-bit 74HC595 shift register driving multiple LEDs

Using the 74HC595 for I/O expansion means that it takes only three MCU control pins to drive up to eight LEDs. Reducing the number of control pins makes it possible to use an MCU with a lower pin count, and that can yield a smaller, more cost-effective design.

Also, because the 74HC595 includes a serial output, several devices can be cascaded together. Figure 2 gives the layout.



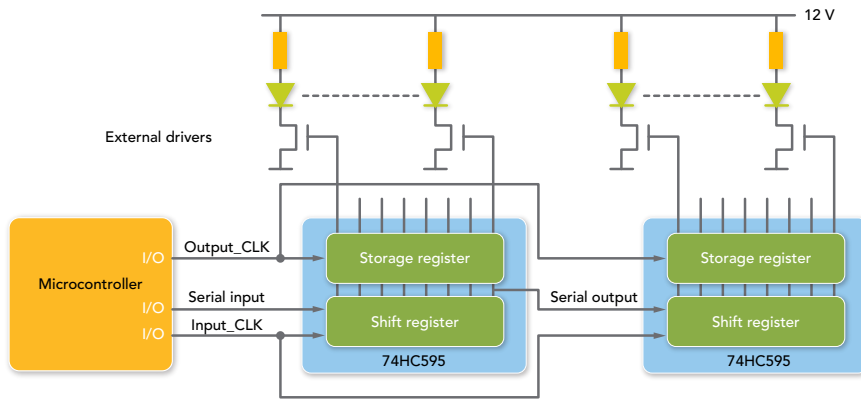

Figure 2. Cascading 74HC595 devices to drive more LEDs

Now, with the cascading, the same three pins on the microcontroller can be used to control up to 16 or 24 LEDs instead of just eight. The ability to cascade shift registers can reduce the total number of microcontrollers needed in the design, and that can help lower costs and reduce size, too.

In some cases, a 5 V, 8-bit register like the 74HC595 can be used to drive LEDs directly. This works best when the LEDs are specified for relatively low voltage and forward current. LEDs that operate with voltages higher than 6 V or require forward current that exceeds 20 mA will typically require an external driver.

Open-drain outputs

Adding open-drain outputs to the shift register creates a single-chip solution that eliminates the need for an external driver. This can yield significant reductions in the bill of materials, since each output of the shift register can drive the LEDs directly.

Figure 3 gives the output schematic for one such device, the NPIC6C596A LED driver from NXP, which combines shift register functions similar to a 74HC595 with a high-voltage (HV) MOSFET driver.

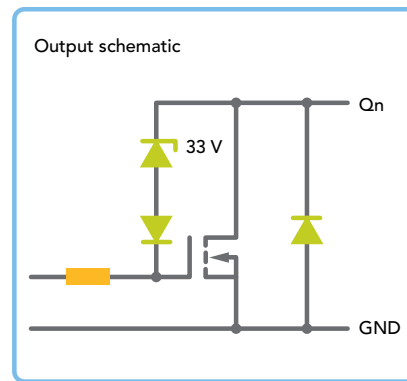

Figure 3. Output schematic for shift register with open-drain outputs

Figure 4 shows the NPIC6C596A used in place of the 74HC595.

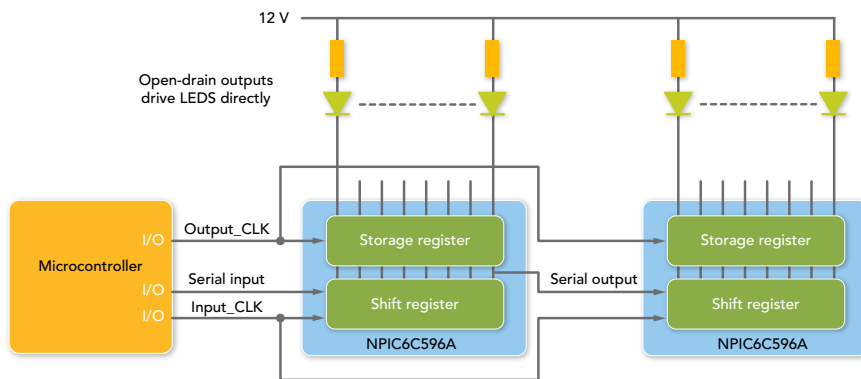

Figure 4. Output schematic for shift register with open-drain outputs

Replacing the 74HC595 with the NPIC6C596A eliminates the need for external drivers, creating a design that is more compact and has a lower bill of materials.

NPIC6C devices have open-drain outputs that are tolerant to 33 V. Each output is designed to sink 100 mA and there is no limit on ground current. All the outputs can actively sink 100 mA simultaneously. The outputs include current-limiting circuitry, which sets a 250 mA maximum on the sinkable current, and each output also includes thermal protection. Having these protections means the NPIC6C596A device can be used to drive a wider range of LEDs than the 74HC595, including LEDs that operate at higher voltages and with higher forward current.

Protection features

Figure 5 shows the behavior of the current-limiting circuitry on the open-drain outputs of the NPIC6C596A. The circuitry limits the maximum current each output can sink. As the drain voltage increases, the drain source current decreases. This protects the outputs and the components they are driving. At 25 °C, the output clamp is typically activated when the drain source current is 250 mA.

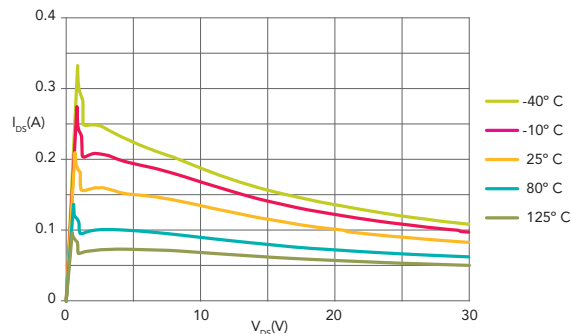

Figure 5. Current-limiting behavior in NPIC6C596A

Figure 6 shows how the open-drain outputs of the NPIC6C596A provide thermal protection. The clamp current is inversely proportional to temperature. As the temperature increases, the output resistance increases, thus limiting the drain source current and preventing damage to the output and the components it drives. At 25 °C, the output typically limits the drain source current to 120 mA.

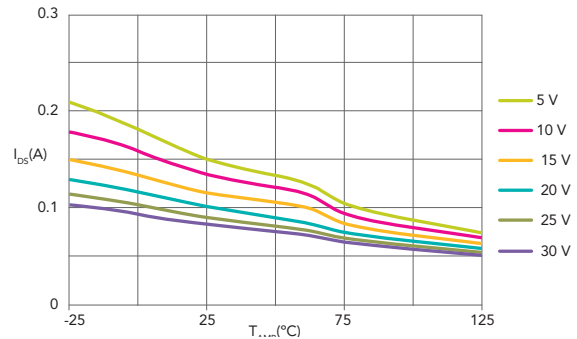

Figure 6. Thermal protection in NPIC6C596A

Multiple options

Table 1 shows the NPIC6C LED drivers available from NXP. The NPIC6C596 and the NPIC6C596A are 8-bit solutions, while the NPIC6C4894 is a 12-bit solution. All include a serial output for cascading. Data is propagated through the shift register on the rising edge of the input clock. With the NPIC6C595 and the NPIC6C4894, the same rising edge is used to clock data to the serial output QS. The NPIC6C596 and NPIC6C596A delay the serial output to the next falling edge of the input clock. The delay provides a longer data hold time, which improves timing margin and makes it easier to cascade many shift registers.





The NPIC6C596 and NPIC6C4894 can be used between 4.5 and 5.5 V, making them suitable for 5.0 V control logic interfaces. The NPIC6C596A can be used from 2.3 to 5.5 V, so it can be used with 5.0, 3.3, and 2.5 V control logic interfaces. All NPIC6C devices operate from -40 to +125 °C and with an input clock frequency of at least 10 MHz.

Table 1. NPIC6C LED drivers from NXP

Type number	Format	Supply voltage (V)	fmax (MHz)	Tamb (°C)	QS clock	Packages
NPIC6C595	8-bit	4.5 to 5.5	10	-40 to +125	Rise	SO16, TSSOP16, DQFN16
NPIC6C596	8-bit	4.5 to 5.5	10	-40 to +125	Fall	SO16, TSSOP16, DQFN16
NPIC6C596A	8-bit	2.3 to 5.5	10	-40 to +125	Rise	SO16, TSSOP16, DQFN16
NPIC6C4894	12-bit	4.5 to 5.5	10	-40 to +125	Rise	SO20, TSSOP20, DQFN20

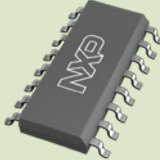
NPIC6C LED drivers are available in industry-standard SO and TSSOP packages, as well as the space-saving DQFN leadless package, which is up to 76 percent smaller than a TSSOP and 40 percent smaller than a QFN. DQFN packages also include a heat sink and are the packages of choice for space-constrained applications that use higher currents. Automotive variants are also available.

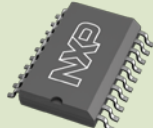
Table 2. Package options for NPIC6C LED drivers

Package suffix	D	PW	BQ	D	PW
	16-pin	16-pin	16-pin	20-pin	20-pin
					
Package	SOT109-1	SOT403-1	SOT763-1	SOT163-1	SOT360-1
Width (mm)	6.00	6.40	2.50	10.30	6.40
Length (mm)	9.90	5.00	3.50	12.80	6.50
Height (mm)	1.75	1.10	1.00	2.65	1.10
Pitch (mm)	1.27	0.65	0.50	1.27	0.65

Conclusion

When LEDs are part of the design, shift registers make it possible to use a smaller, less expensive microcontroller. Standard 8-bit shift registers like the 74HC595 are available from a number of suppliers, including NXP. Shift registers that are equipped with open-drain outputs, like the NPIC6C series from NXP, go a step further, because they eliminate the need for external LED drivers.

More about the NPIC6C series can be found at <http://www.nxp.com/products/logic/family/NPIC/#overview>